



CUNOVA

FORMERLY KME
SPECIAL PRODUCTS
& SOLUTIONS



Service Portfolio



**MELTING & CASTING
SERVICES**

CONTENT

The Company	03
Continious Casting Equipment	04
Caster Mould	05
Caster Segments	06
Mill Rolls	07
Chocks / Bearings / Sleeves	08
Billet Moulds	09
Aditonal Equipment	10
cunova Service Center	11

The Company

cunova's corporate goal is to develop and manufacture products that meet customer demands, finding solutions for their specific applications, and providing services as a long-term partner. cunova's strategy for accomplishing this goal is based on a highly skilled and experienced workforce. cunova has the ability to invent and develop new materials and innovative production processes via ongoing advancement and training of our employees and the continual improvement of its organisational structures.

Melting & Casting Services

Mould Assemblies

From the smallest size billet mould to remotely adjustable slab moulds – cunova builds and assembles all types of casting moulds complete with their complex drive and control systems.

Here, too, the uncompromising quality standards of cunova are ensured through in-process quality control at all stages of a project, no matter whether it is a one-off job or the manufacture and assembly of a whole series of moulds. These services for maintenance and re-coating are for customer's requirements on a worldwide basis.

Repair of Mould Tubes

As a matter of basic principle, mould tubes are designed as expendable items. Yet, in certain cases it may be economically worthwhile for a client to have his large-section mould tubes reworked.

Repair of Mould Plates

cunova's maintenance and repair services for mould plates include the proper remachining as well as repair of stud-welded moulds and possible re-coating of the copper, plus a complete overhaul of the entire mould assembly, if needed.

In the case of a complete mould overhaul, the mould will be dismantled and all its mechanical and supporting parts will be inspected and, if necessary, renewed. Like cunova's newly built moulds, the reassembled unit complete with the remachined copper – or with new copper, if necessary – will undergo a complete operational check.

CONTINUOUS CASTING EQUIPMENT

Your full service provider for continuous casting equipment

We offer complete refurbishment / design modifications and upgrades for all Continuous caster components from the Tundish to the cutting torch. We also provide new components such as Molds, Segments, Dummy

bar chains, conveyor chains, fabrications of all sizes, new copper plates, new roll forgings, Oscillators refurbishments, on site equipment installations and equipment alignment.

Steel Production

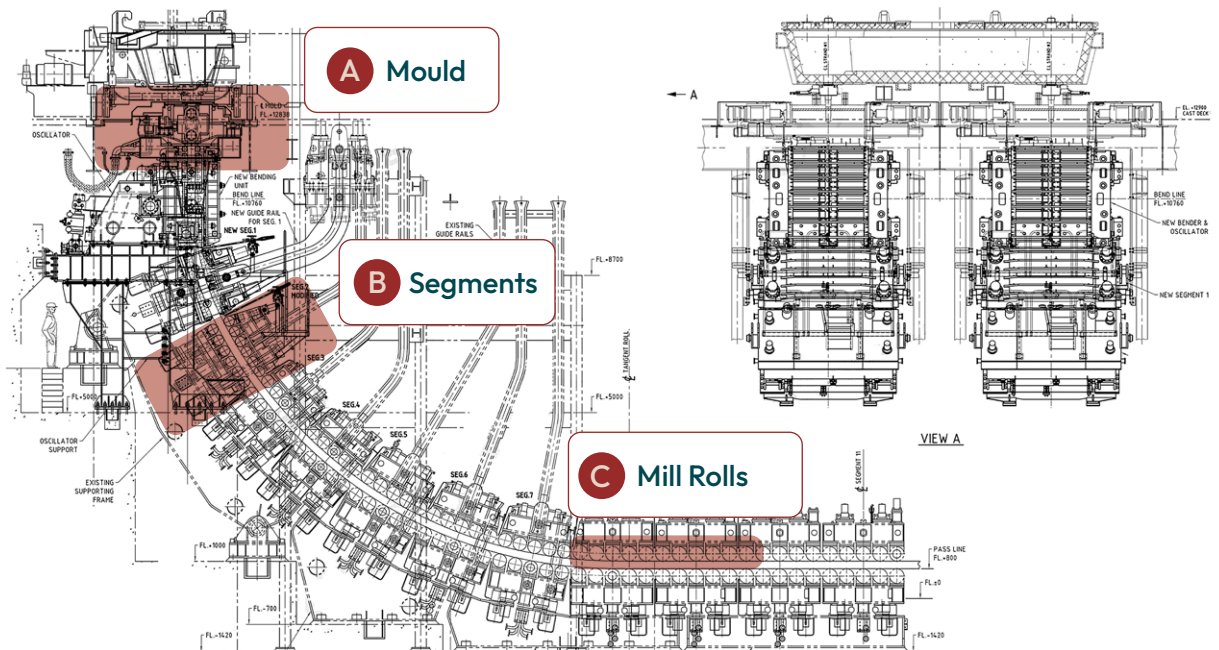

Steel Finishing

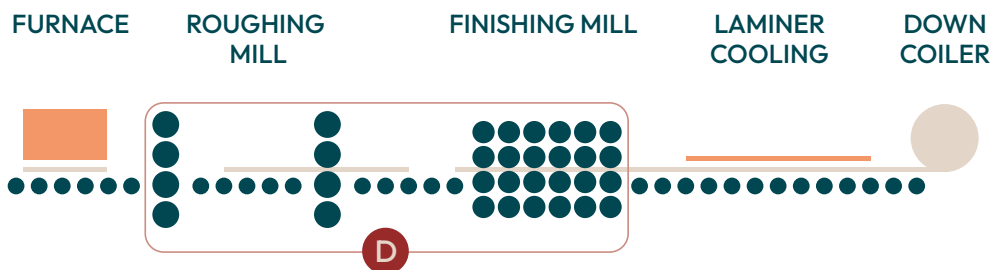

A > Caster Mould and Copper

B > Caster Segments

C > Mill Rolls

D > Chocks / Bearings / Sleeves

CONTINUOUS CASTING EQUIPMENT

Caster Mould

We offer complete mold refurbishments, gearbox refurbishment, hydraulic cylinder refurbishment, end wall alignments and rebuilds, frame qualifications, etc.

and a variety of patented coatings for broadface and narrowface coppers.

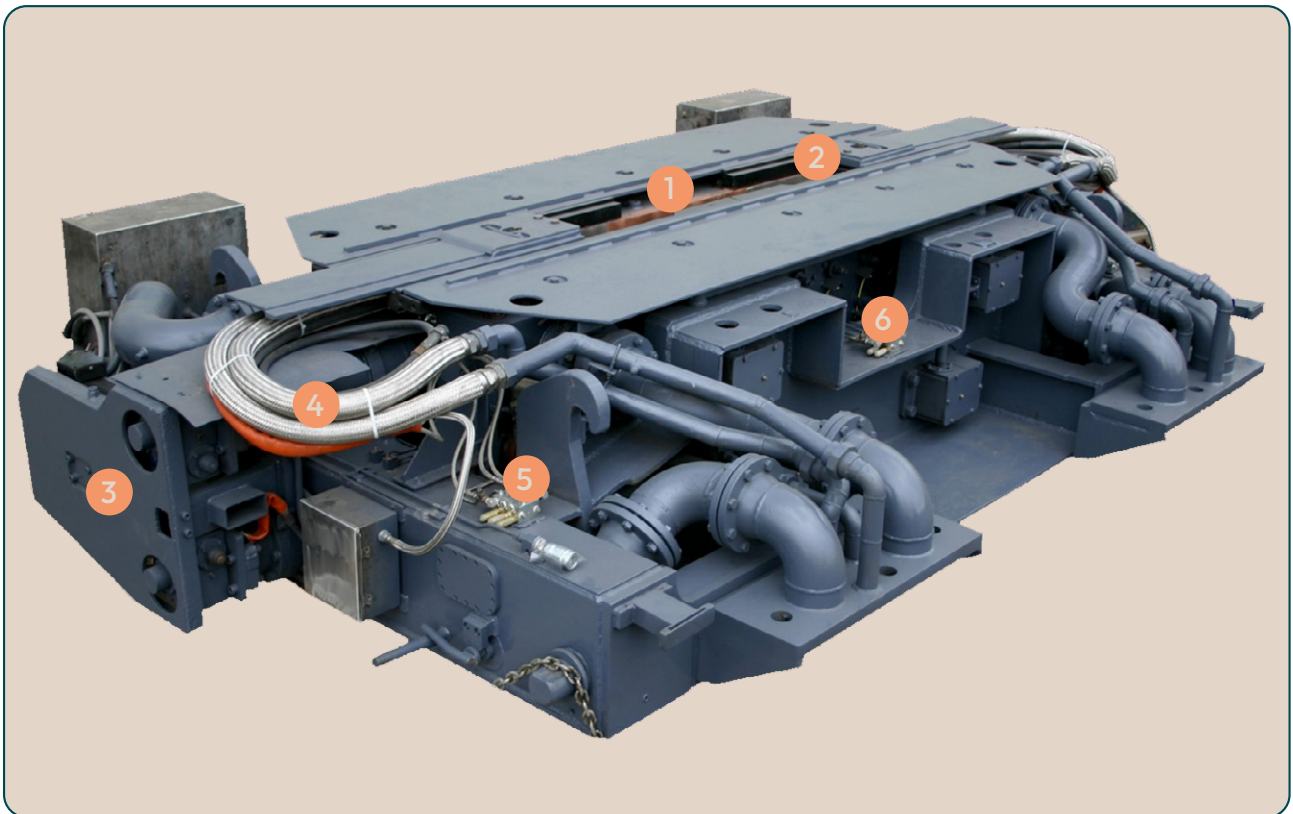

- 1 > Broadface Coppers
- 2 > Narrowface Coppers
- 3 > Gearboxes & Motors

- 4 > Water Cooling & Spray Systems
- 5 > Lubrication Systems
- 6 > Hydraulic Systems

Caster Segments

Complete and conditional based rebuilds, hydraulic system design and installation, grease system replacement and repair, Air/Oil system design and implementation, roll alignment, frame qualification and

repair, new components fabrication, complete roll repair and overlay capabilities, bearing housing replacement and repair, bearing failure analysis, bearing reclamation programs, chemical cleaning of internal water passages.

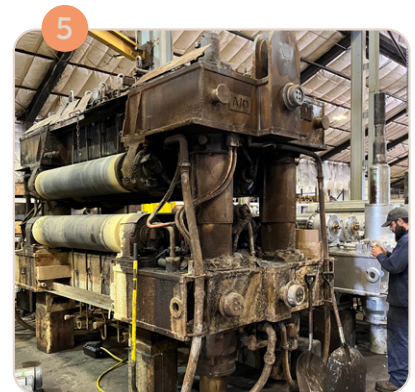
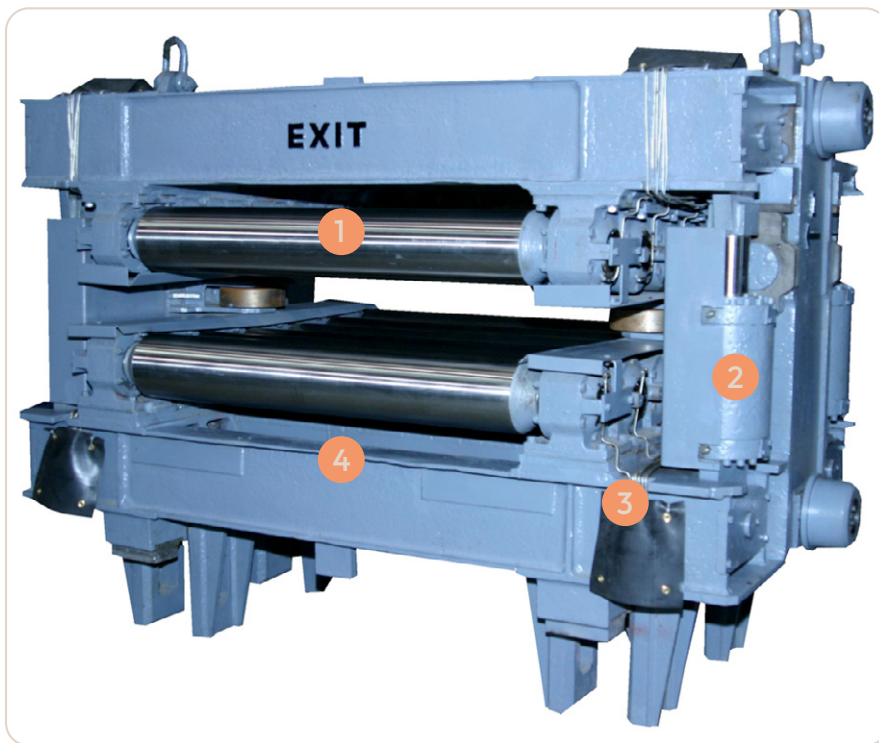

Slab Caster Segment

- 1 > Rollers
- 2 > Hydraulic Systems
- 3 > Lubrication Systems
- 4 > Cooling & Spraying Systems
- 5 > Caster Segment before processing

Mill Rolls

We offer complete refurbishment of all mill rolls – Segment rolls, table rolls, withdrawal rolls, straightener

rolls, run out rolls, downcoiler rolls, pinch rolls, descale rolls, etc. All types of rolls are offered new as well.

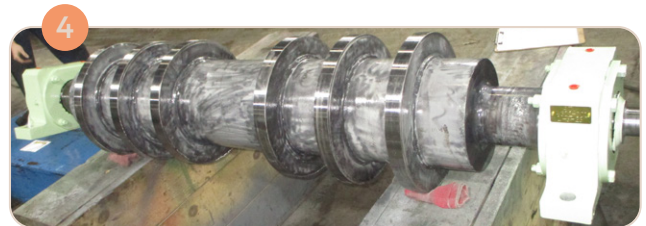
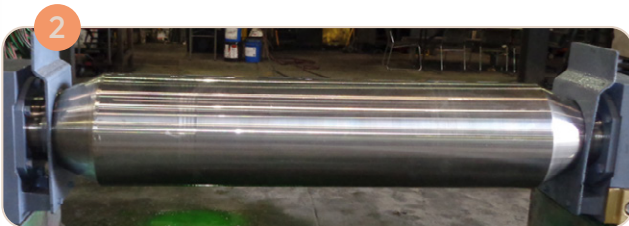
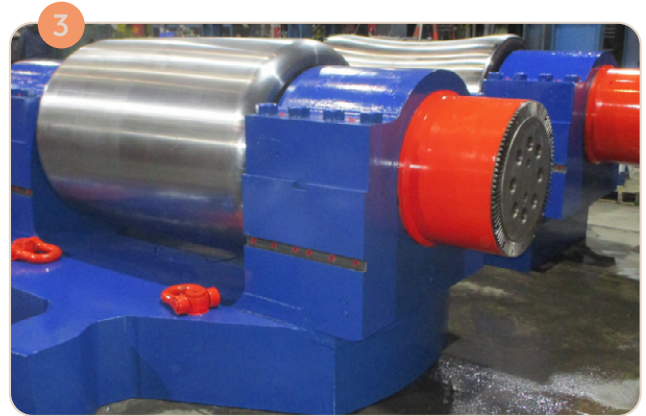

1 > Straightener Rolls

2 > Withdrawal Rolls

3 > IFL Rolls

4 > Table Rolls

CONTINUOUS CASTING EQUIPMENT

Chocks / Bearings / Sleeves

We offer complete refurbishment of work roll and back-up chocks, Babbitt bushings, Babbitt sleeves, Taper neck Sleeves (10" to 80" in diameter), Pinion Stands, Gear Drives, grinder blocks, and Power Industry / Power Generation Bearings.

We are also specialised in Rings, inboard / outboard ring spacers, throw rings and gib blocks. Other offerings include High technology coatings, as well as onsite inspections and equipment installations.



1 > Chock Assembly

2 > Babbitt Bearing

3 > Tapered Sleeve

CASTING EQUIPMENT

Billet Moulds

We offer complete refurbishment of moulds, water jackets and other spares around the mould. We provide personalised solutions like engineering and supply of

revampings of existing machines, transformation to hydraulic mould oscillation or movable slag box system or head and tail deburring systems, etc.

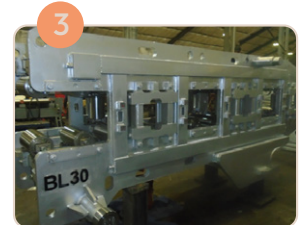
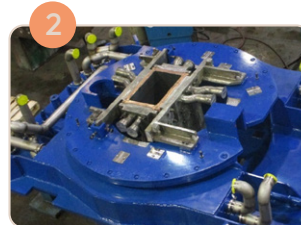
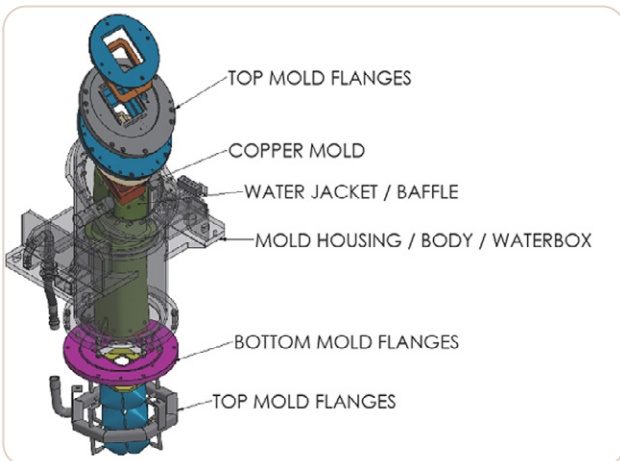

- 1 > Foot Roller Assemblies
- 2 > Bloom Mould Support
- 3 > Alignment Systems

- 4 > Segment Frames
- 5 > Beam Blank Waterjacket

ADDITIONAL EQUIPMENT

Further Service Areas

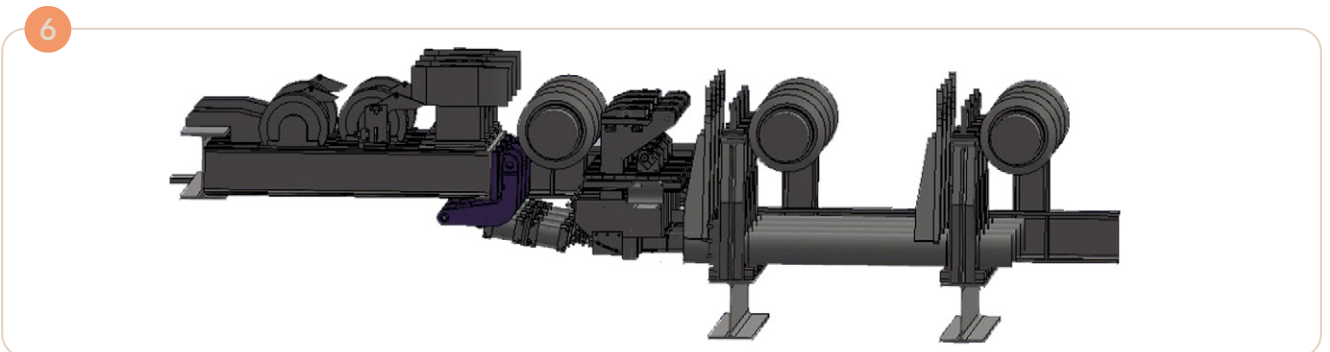

- 1 > Dummy Bar Chains
- 2 > Segment Rollers
- 3 > Oscillators

- 4 > 600rd Waterjacket
- 5 > Conveyor Chain
- 6 > Deburring Systems

CUNOVA SERVICE CENTER

Service wherever and whenever you need it

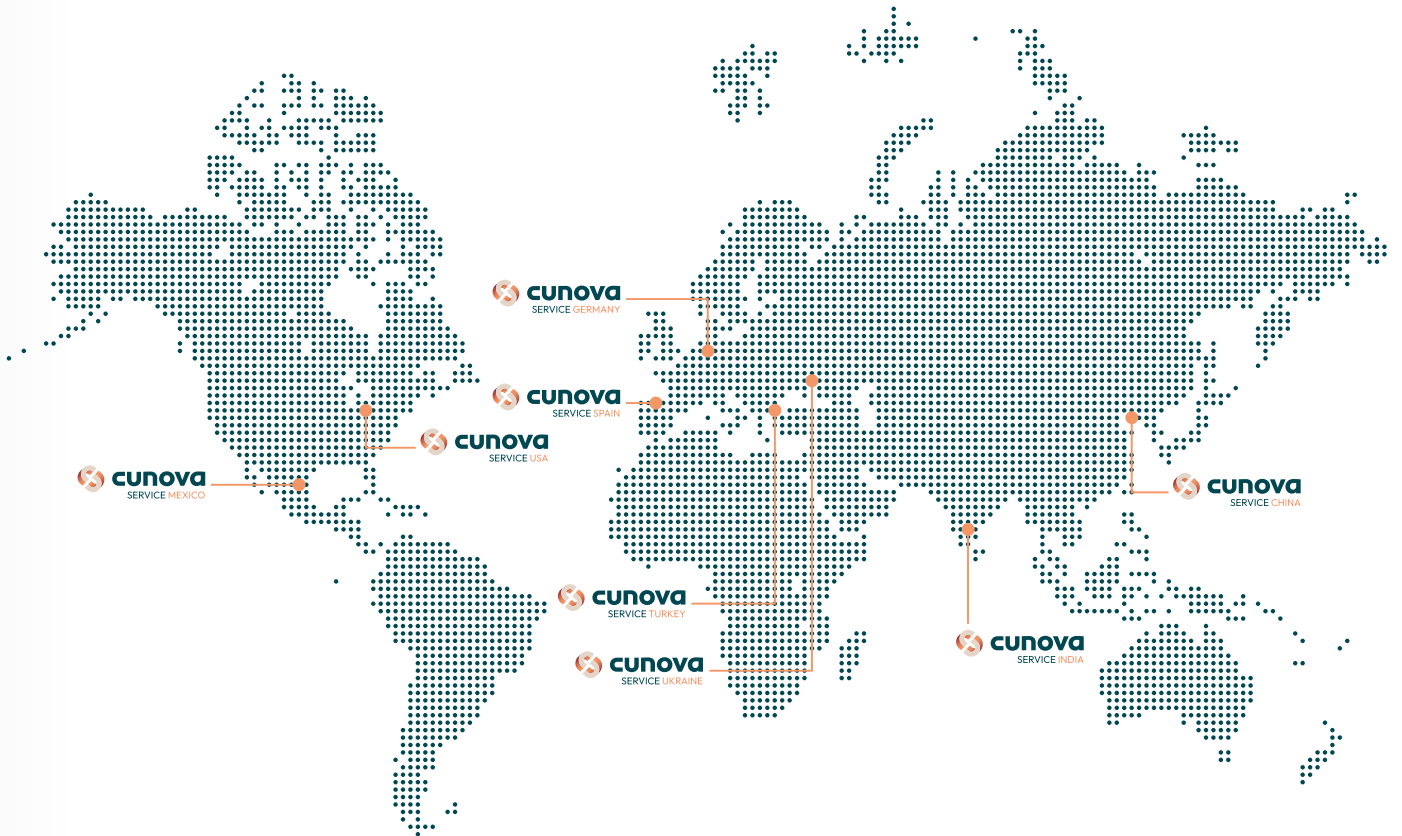

 **cunova**
SERVICE CHINA China
M: info@cunova.com

 **cunova**
SERVICE GERMANY Germany (Osnabrück)
cunova GmbH
T +49 541 321-3218 | M: info@cunova.com

 **cunova**
SERVICE INDIA India (Bangalore)
cunova Service India Pvt. Ltd.
T: +91 966 331 4751 | M: prashant@cunova.in

 **cunova**
SERVICE MEXICO Mexico (Monterrey)
cunova Service Mexico S.A. de C.V.
T: +51 818 308 6810 | M: luis.iracheta@cunova.mx

 **cunova**
SERVICE SPAIN Spain (Gallarta – Abanto Vizcaya)
cunova Service Spain S.A.
T: +34 946 360 128 | M: info@cunova.es

 **cunova**
SERVICE TURKEY Turkey (Gebze)
cunova Kalıp Servis Sanayi ve Ticaret A.Ş.
T: +90 212 244 7460 | M: cem.oz@kmeikalip.com

 **cunova**
SERVICE UKRAINE Ukraine (Mariupol)
cunova Magma Service
M: info@cunova.com

 **cunova**
SERVICE USA USA (Titusville)
cunova Service USA LLC
T: +1 814 827 7717 | M: sales@cunova.us



FORMERLY KME
SPECIAL PRODUCTS
& SOLUTIONS

Further information on Service Capabilities:

Reinhard Hintemann
Head of cunova Service Europe
T +49 541 321-3400
reinhard.hintemann@cunova.com

Marc Brörmann
Head of Sales cunova Service Europe
T +49 541 321-3244
marc.broermann@cunova.com

www.cunova.com

cunova GmbH
Klosterstrasse 29
49074 Osnabrück
Germany